

VERTICAL MASTS



STAR 22 J / 26 J

Optimal agility in confined working areas

- Progressive electric drive AC motors
- Tight turning radius
- Vertical jib allowing 9 ft 10 in outreach

Minimal maintenance and downtime

- Maintenance free brushless AC motors
- Haulotte Activ'Screen onboard diagnostic tool
- Centralized battery filling

Longer life time

- New ultra-resistant hoods in composite material
- Durability increased on pins, bushings, non-painted parts, and fastening hardware

Smarter transport

- Versatile and effective transport solutions with forklift pockets
- 25% gradeability to easily climb truck ramps



Haulotte 

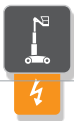

STAR 22 J / STAR 26 J



VERTICAL MASTS

TECHNICAL DATA

STAR 22 J

STAR 26 J

Working height	28 ft 2 in	32 ft 1 in
Platform height	22 ft 2 in	26 ft 1 in
Horizontal outreach	9 ft 10 in	9 ft 10 in
Lift capacity	500 lbs	500 lbs
Platform size	2 ft 7 in x 3 ft 3 in	2 ft 7 in x 3 ft 3 in
D Length	8 ft 10 in	8 ft 10 in
B Width	3 ft 3 in	3 ft 3 in
A Height - stowed	6 ft 6 in	6 ft 6 in
Tailswing	0 in	0 in
C Wheelbase	3 ft 11 in	3 ft 11 in
E Ground clearance	4 in	4 in
Driveable at full height up to	22 ft 2 in	26 ft 1 in
Drive speed	0.4 - 3.1 mph	0.4 - 3.1 mph
Turning radius - outside	6 ft 2 in	6 ft 2 in
Turntable rotation	345°	345°
Vertical jib rotation	130° (+70°/-60°)	130° (+70°/-60°)
Tires	16x5x10.5	16x5x10.5
Tilt alarm	3 °	3 °
Gradeability	25 %	25 %
Hydraulic tank capacity	1.85 gal	2 gal
Batteries	24 V - 250 Ah	24 V - 250 Ah
Weight	6,260 lbs	6,400 lbs

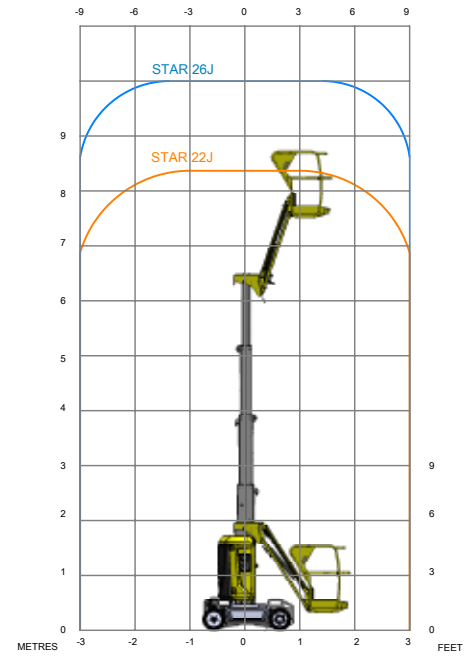

STANDARD EQUIPMENT

- 24 V electric drive brushless AC motors
- 24 V – 250 Amph traction batteries
- 35A battery charger
- Battery charge indicator
- Haulotte Activ'Screen on-board diagnostic tool
- Centralized battery filling
- Forklift pockets
- Towing hooks and lifting eyes
- Pothole protection
- 2 Rear steering wheels
- 2 front driving wheels
- Non-marking tires
- Brake release
- Hourmeter
- Horn
- Emergency stop buttons at cage and ground level
- Load controller in the platform
- Emergency hand pump
- 2 control stations - in the basket and at ground level
- 2 Lanyard attachment points
- Travel alarm

OPTIONS AND ACCESSORIES

- Maintenance-free batteries
- Swing door entry gate (Standard on US machines)
- Haulotte ACTIV'SHIELD™ Bar
- Flashing light
- Working light
- AC Power to the platform (Standard on US machines)
- Air line to the platform
- Hydraulic oil for cold climates
- Biodegradable oil

