

COMPACT CRAWLER BOOM LIFTS



JLG
reachingout®

COMPACT CRAWLER BOOMS REACHING OUT

Now you can go more places around the job site thanks to the low weight and non-marking tracks on the Compact Crawler boom. Available in four models with working heights ranging from 50 ft to 84 ft, JLG® Compact Crawler boom lifts feature a tracked wheel carriage that climbs steps and a narrow chassis for access through doorways, gates and yards.

"Jobs that used to require tricky positioning are much easier to access now."



The X430AJ, X500AJ and X600AJ fit through single doors.



The X770AJ can go through double doors.



X430AJ

Platform Height: 43' 6" (13.30 m)
Working Height: 50 ft (15.40 m)
Horizontal Outreach: 21' 7" (6.60 m)
Platform Capacity: 500 lb (227 kg)

Platform
Working
Horizontal
Platform



X500AJ

Platform Height: 49' (14.95 m)
Working Height: 56' (17.06 m)
Horizontal Outreach: 23' (7.00 m)
Platform Capacity: 500 lb (227 kg)



X600AJ

Platform Height: 59' 3" (18.05 m)
Working Height: 66' (20.11 m)
Horizontal Outreach: 30' (9.20 m)
Platform Capacity: 500 lb (227 kg)



X770AJ

Platform Height: 77' 5" (23.60 m)
Working Height: 84' (25.60 m)
Horizontal Outreach: 43' (13.1 m)
Platform Capacity: 500 lb (227 kg)



ALL OF YOUR OVERHEAD TASKS WITHIN REACH

Whether you're working indoors or outside, the Compact Crawler Boom has your job covered. With enhanced maneuverability and better access, you've got the ability to go more places thanks to its low profile, non-marking tracks and compact dimensions. The compact crawler is easy to operate with one-touch outrigger leveling, an interactive display in the platform and controls. And because the compact crawler is so lightweight, it can be set up on sensitive flooring and landscaping.

These machines are environmentally friendly with an optional market-leading Lithium-ion battery power system for clean, quiet, green operation. All models now offer the added benefit of a fully synthetic biodegradable hydraulic fluid. Other features include an articulating jib for greater reach, rotation of platform and zero-turn radius with counter rotation.

FORK POCKETS AND LIFT HOOKS

Are available on all models.



"While indoors, I can quietly operate at full speed thanks to the Lithium-ion battery. Plus, I can easily fit through narrow doorways."

FEATURES



Optional Flashing Beacon and Quick-Start Advance Technology Lithium-ion Power System

Produces zero emissions and quiet operation.



Ease of Transport

Fits on a trailer or tilt-back truck (low weight, good gradeability, compact).

Compact Crawler Booms
BOOM LIFTS



SkyGuard®
SkyGuard® enhanced operator protection is standard on all models



Platform Caster Wheels
Push around detached platform with ease thanks to caster wheels on all models.



PUTTING YOUR WORK ABOVE EVERYTHING

When it comes to JLG® Support, it's all about you. Your productivity. Your profitability. Your uptime. From the purchase of your first piece of equipment straight through to the training, parts and maintenance that follows.

■ Customer Service Call Center

You can be assured we'll be giving an all-out effort to support you. Just think of us as your personal on-call, full-service support team. We make it happen. Period.

■ Financial Solutions

Maximizing your profits. Preserving your cash flow. Let our financing specialists help choose the program designed specifically for your needs.

■ Aftermarket Parts

Keep your equipment running at peak performance with genuine replacement parts, accessories, attachments, rebuilt and competitive parts all from one source — JLG.

■ Training

Knowing your equipment inside and out results in higher productivity on the job. Our instructor-led courses give you the hands-on time you need to successfully operate equipment.

■ Service Centers

Your needs. Your uptime. JLG is on the job to fulfill your every need, from repair, reconditioning, same-day parts and much more. We're here to support you.

■ Pre-Owned Equipment

As a high-value alternative to purchasing new equipment, you can search our used equipment inventory of pre-owned JLG and competitor products.

Compact Crawler Booms SPECIFICATIONS

	X430AJ	X500AJ	X600AJ	X770AJ
Platform Height	43' 6" (13.30 m)	49' (14.95 m)	59' 3" (18.05 m)	77' 5" (23.60 m)
Working Height	50' (15.40 m)	56' (17.06 m)	66' (20.11 m)	84' (25.60 m)
Horizontal Outreach	21' 7" (6.60 m)	23' (7.00 m)	30' 2" (9.20 m)	43' (13.1 m)
Swing	360° Non-continuous	360° Non-continuous	360° Non-continuous	360° Non-continuous
Platform Capacity Restricted	500 lb (227 kg)	500 lb (227 kg)	500 lb (227 kg)	500 lb (227 kg)
Platform Capacity Unrestricted	500 lb (227 kg)	500 lb (227 kg)	500 lb (227 kg)	500 lb (227 kg)
Platform Rotation	124° (+/- 62°)	124° (+/- 62°)	124° (+/- 62°)	124° (+/- 62°)
Jib (Range of Articulation)	89° (0/-89)	89° (0/-89)	89° (0/-89)	89° (+0° / -89°)
Platform Size Standard Two person Optional Single person	58" x 30" (1.47 x 0.76 m) 31" x 24" (0.78 x 0.61 m)	58" x 30" (1.47 x 0.76 m) 31" x 24" (0.78 x 0.61 m)	58" x 30" (1.47 x 0.76 m) 31" x 24" (0.78 x 0.61 m)	58" x 30" (1.47 x 0.76 m) 31" x 24" (0.78 x 0.61 m)
Overall Width	29" (0.75 m)	31" (0.78 m)	31" (0.78 m)	39" (0.99 m)
Stowed Height	6' 6" (1.99 m)	6' 6" (1.99 m)	6' 6" (1.99 m)	6' 6" (1.99 m)
Outrigger Footprint Narrow	9' 8" x 9' 8" (3.0 m x 3.0 m) N/A	10' 5" x 10' 5" (3.17 x 3.17 m) N/A	10' 7" x 10' 7" (3.2 x 3.2 m) N/A	14' 3" x 14' 6" (4.31 x 4.41 m) 9' 3" x 19' 2" (2.81 x 5.84 m)
Stowed Length Without Basket	13' 2" (4.02 m) 11' 2" (3.40 m)	14' 10" (4.53 m) 13' 8" (4.16 m)	16' 5" (5.01 m) 15' 3" (4.65 m)	20' 9" (6.34 m) 19' 7" (5.98 m)
Track Length	4' 1" (1.24 m)	4' 1" (1.24 m)	4' 10" (1.47 m)	6' 10" (2.10 m)
Weight* (Lithium Ion)	4,392 lb (1,992 kg)	5,071 lb (2,300 kg)	6,571 lb (2,980 kg)	9,665 lb (4,384 kg)
Ground Bearing Pressure Outriggers Tracks	34.1 psi (2.40 kg/cm ²) 8.20 psi (0.58 kg/cm ²)	35.53 psi (2.49 kg/cm ²) 9.72 psi (0.68 kg/cm ²)	44.09 psi (3.09 kg/cm ²) 9.28 psi (0.65 kg/cm ²)	65.3 psi (4.50 kg/cm ²) 7.8 psi (0.54 kg/cm ²)
Drive Speed (Lithium Ion)	0.87 mph (1.4 km/h)	0.8 mph (1.3 km/h)	0.8 mph (1.3 km/h)	0.7 mph (1.2 km/h)
Gradeability	28%	28%	28%	28%
Leveling Capability	12°	12°	15°	16°
Gasoline Engine	Honda iGX390 11.7 hp (8.7 kW)	Honda iGX390 11.7 hp (8.7 kW)	Honda iiGX440 13 hp (9.5 kW)	—
Diesel Engine	—	—	—	Diesel Kubota D902 21.6 hp (16.1 kW)
Electric Engine	100Ah 36V Lithium-Ion	100Ah 48V Lithium-Ion	100Ah 72V Lithium-Ion	100Ah 83V Lithium-Ion
Fuel Tank Capacity (Gasoline)	1.4 gal. (5.3 L)	1.4 gal. (5.9 L)	1.4 gal. (5.9 L)	6.6 gal. (25 L)
AC Motor**	120V 60 Hz (1.2 kW)	120V 60 Hz (1.2 kW)	120V 60 Hz (1.2 kW)	120V 60 Hz (1.2 kW)

*Certain options or country standards increase weight.

**Country specific options available.

X430AJ

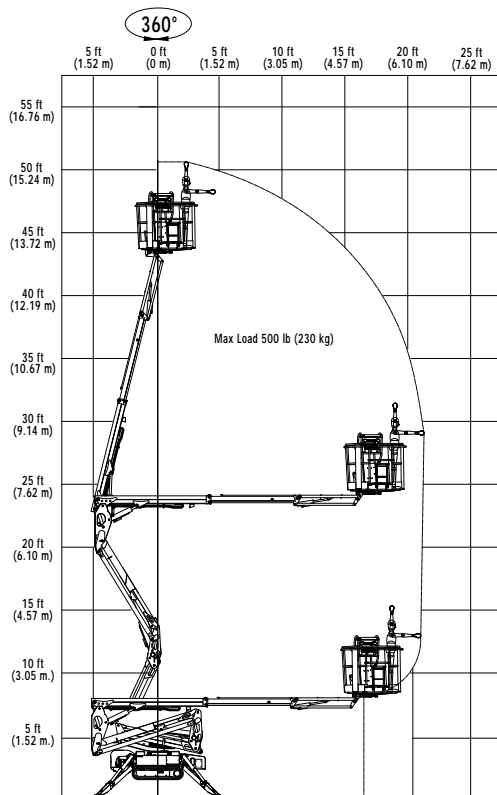
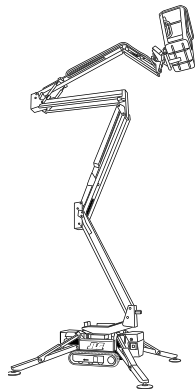

X500AJ

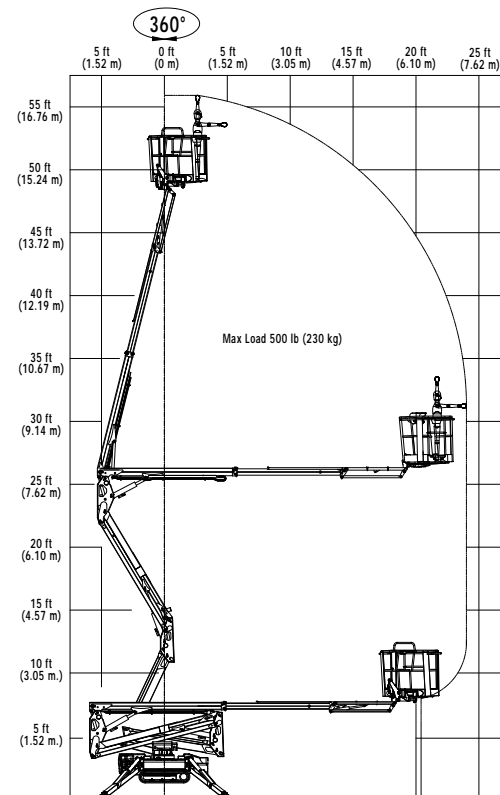

Main Features

- Optional Lithium-ion power available.
- One-touch outrigger leveling.
- 110V-AC receptacle in platform.
- Standard air/water line.
- Patented quick connect platform.
- Large Teflon outrigger pads.
- LCD panel provides onboard diagnostics.
- SkyGuard®
- Fork Pockets and Lift Hooks.
- Caster Platform Wheels.
- Fully Synthetic Biodegradable Hydraulic Fluid.
- Optional Beacon Light.

X600AJ

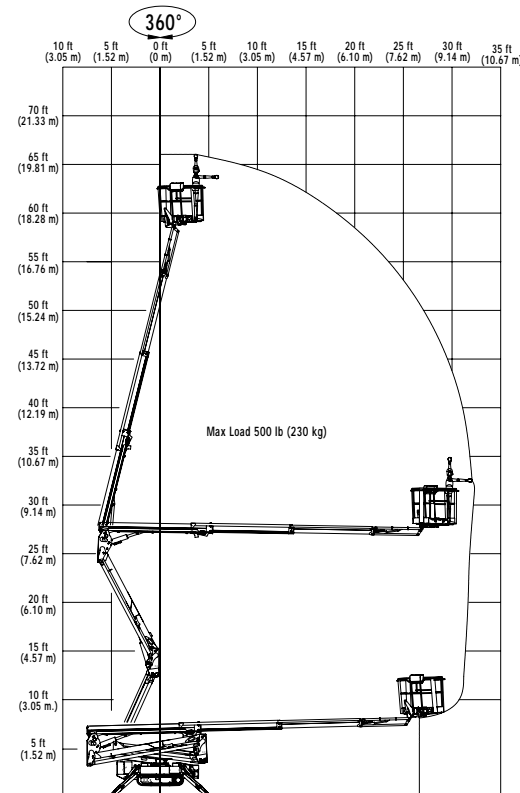

X770AJ

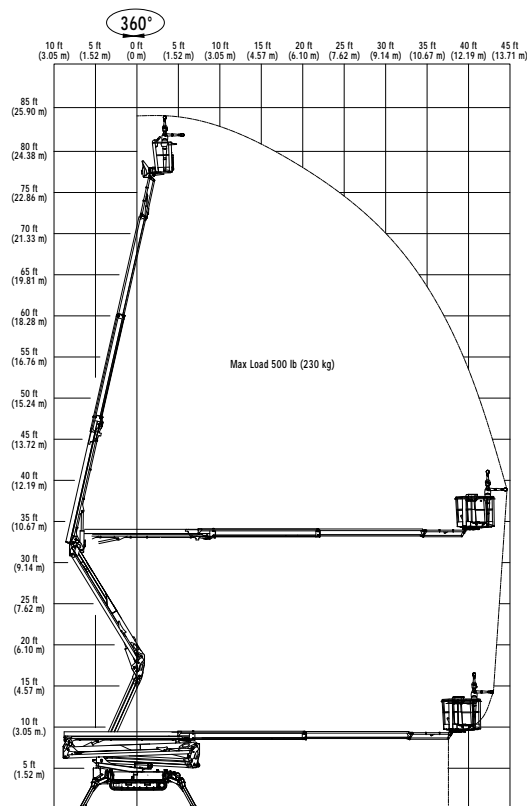

JLG Industries, Inc.

1 JLG Drive
 McConnellsburg, PA 17233-9533
 Telephone 717-485-5161
 Toll-free in US 877-JLG-LIFT
 Fax 717-485-6417

www.jlg.com

An Oshkosh Corporation Company

Part No.: 3131582
 R011713
 Printed in USA

